

D C B A

REVISIONS					
ZONE	LTR	BY	DESCRIPTION	DATE	APPROVED

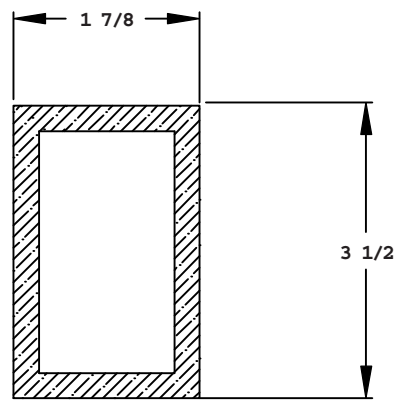
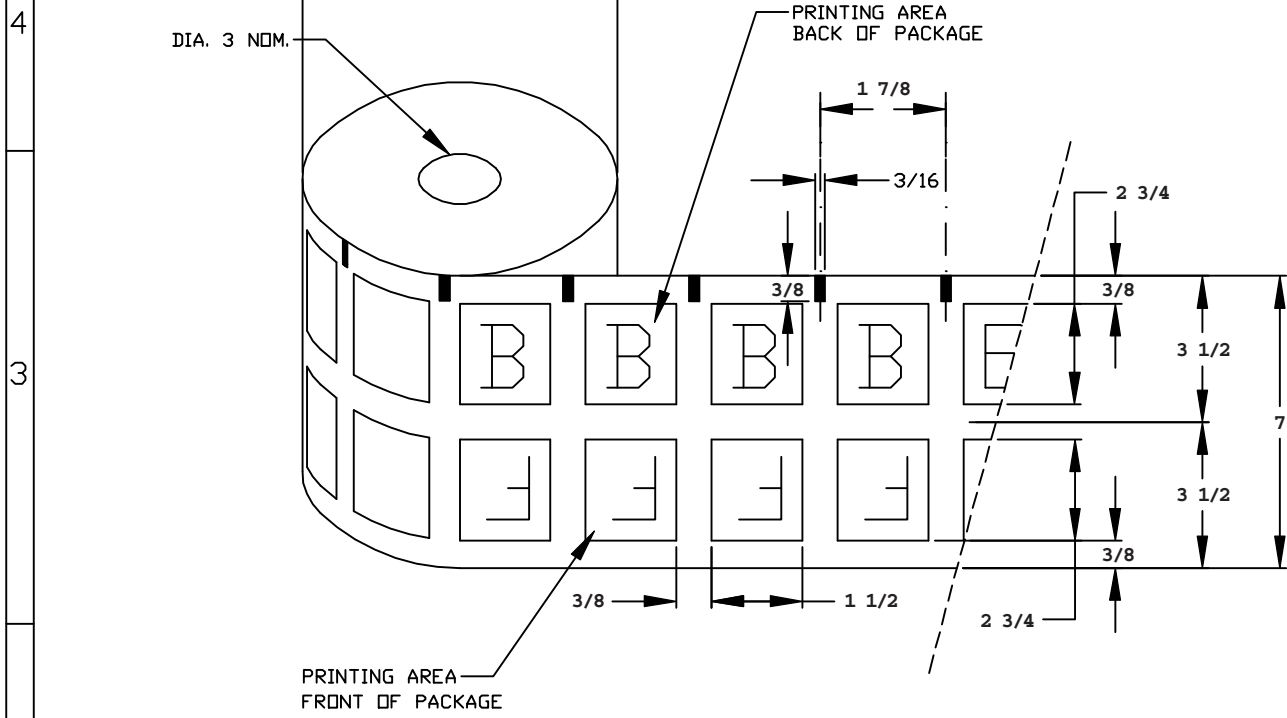

4 SIDE - SEALED

PRINTING AREA FRONT OF PACKAGE

PRINTING AREA BACK OF PACKAGE

FILM DIRECTION IN MACHINE

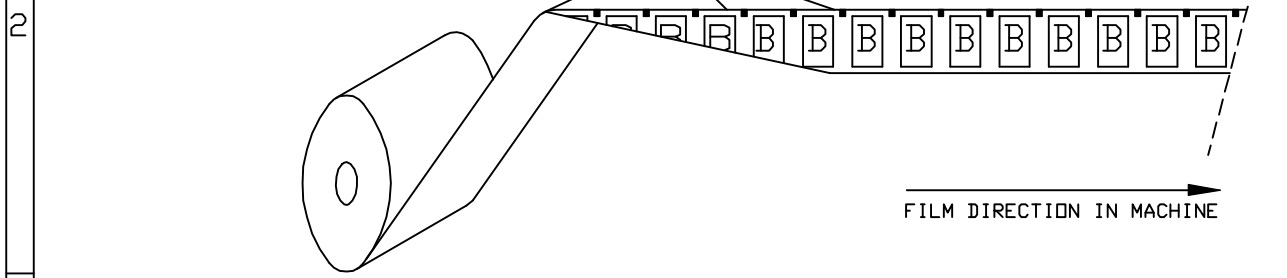

- NOTE:**
1. DIMENSIONS ARE IN INCHES
 2. MAXIMUM OF 1 SPLICE PER ROLL
 3. FRONT PRINT AREA 3" X 1 1/2"
 4. BACK PRINT AREA 2 3/4" X 1 1/2"

NOTICE: THIS DOCUMENT CONTAINS INFORMATION PROPRIETARY TO NATIONAL TOWELETTE COMPANY. REPRODUCTION OR DISSEMINATION OF INFORMATION PROVIDED HEREIN, OR OTHER USE NOT AUTHORIZED IN WRITING BY NATIONAL TOWELETTE COMPANY IS STRICTLY PROHIBITED.			NATIONAL TOWELETTE COMPANY 1400 TAYLORS LANE CINCINNATI NJ 07077	
MATERIAL	HEAT TREATMENT	FINISH	DRAWN	DATE
N/A	N/A	N/A	PSC	5/23/02
ALL TOLERANCES UNLESS OTHERWISE SPECIFIED			CHECKED	DATE
2 PLACE DECIMALS .010			DESIGNER	DATE
3 PLACE DECIMALS .005			ENGINEER	DATE
4 PLACE DECIMALS .0005			TITLE	
SCALE NTS		NEXT ASSY:		SHT1 of 1
SIZE		DWG. NO. KB1.875x3.5		REV