

REVISIONS					
ZONE	LTR	BY	DESCRIPTION	DATE	APPROVED

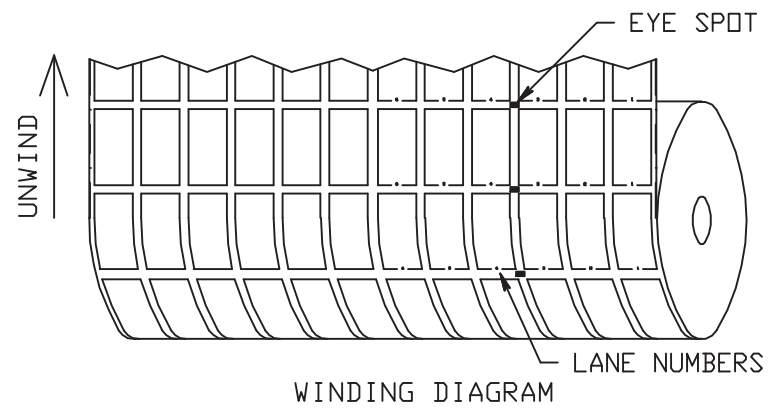

LANE NUMBER 0, 10 HIGH 6 TO 1 AS SHOWN

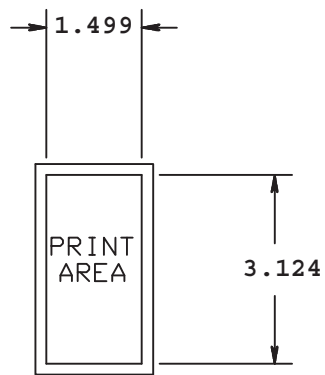

NOTES:

1. EYE SPOT MUST BE HIGH TEMPERATURE INK IF SURFACE PRINTED.
2. REPEAT TOLERANCE ON EYE SPOT TO BE +/- .015 PER REPEAT, TOTAL TOLERANCE ON 10 REPEATS NOT TO EXCEED +/- .062
3. EYE SPOTS MUST BE A CONTRASTING OPAQUE COLOR.
4. MAX. ROLL DIA. 19.00", CORE DIA. NOMINAL 3".
5. INCLUDE LANE NUMBER ON BACK OF EACH PACKET AS SHOWN.
6. DRAWING NOT TO SCALE

NOTICE: THIS DOCUMENT CONTAINS INFORMATION PROPRIETARY TO NATIONAL TOWELETTE COMPANY. REPRODUCTION OR DISSEMINATION OF INFORMATION PROVIDED HEREIN, OR OTHER USE NOT AUTHORIZED IN WRITING BY NATIONAL TOWELETTE COMPANY IS STRICTLY PROHIBITED.				NATIONAL TOWELETTE COMPANY 1400 TAYLORS LANE CINNAMINSON NJ 08077	
MATERIAL	HEAT TREATMENT	FINISH	DRAWN	DATE	TITLE
			PSC	9/24/02	WEB LAYOUT FOR 6 LANE x" TOWELETTE
ALL TOLERANCES UNLESS OTHERWISE SPECIFIED			CHECKED	DATE	SIZE
			DESIGNER	DATE	DWG. NO. 1.875x3.5
			ENGINEER	DATE	REV
SCALE N.T.S.				NEXT ASSY:	SHT of